

REV.	DESCRIPTION	DATE

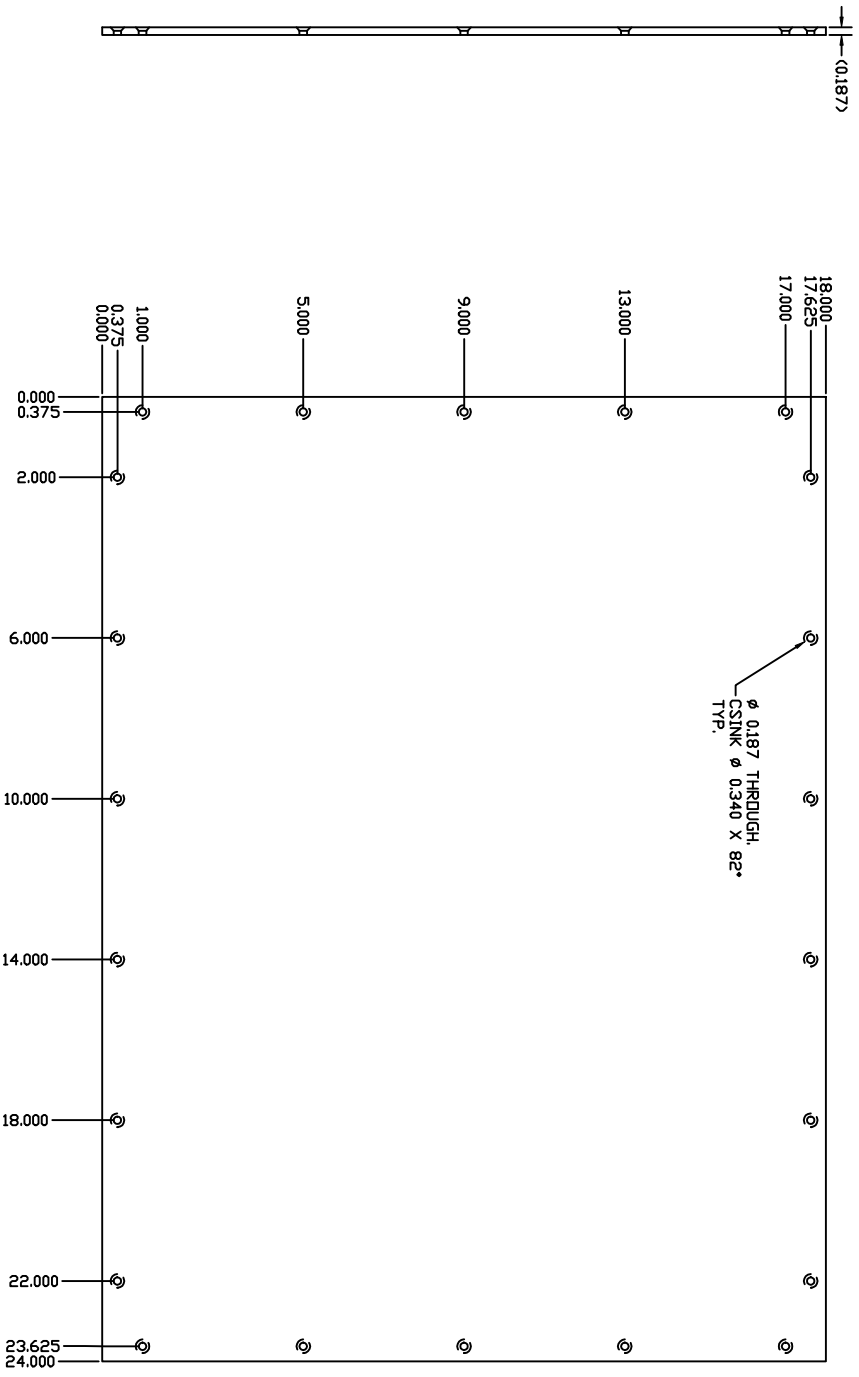

UNLESS OTHERWISE SPECIFIED DIMENSIONS ARE IN INCHES TOLERANCES ARE: X=±.03    ANGLES=0° 30" XX=±.01 XXX=±.005 FINISH:	TITLE	SIGNATURE	DATE
	DR.	MIKE CURTIS	5/30/02
	CHK.		
MATERIAL:	APP.		
TITLE 4.0 EC 18X24 BOARD PLATE S1			

LEXAN	SIZE	DWG. NO.	REV
	A	4.0 EC 18X24 BOARD S1	
SCALE	NONE	SHEET	1 OF 5

NOTES:  
(UNLESS SPECIFIED)

# VIEW B

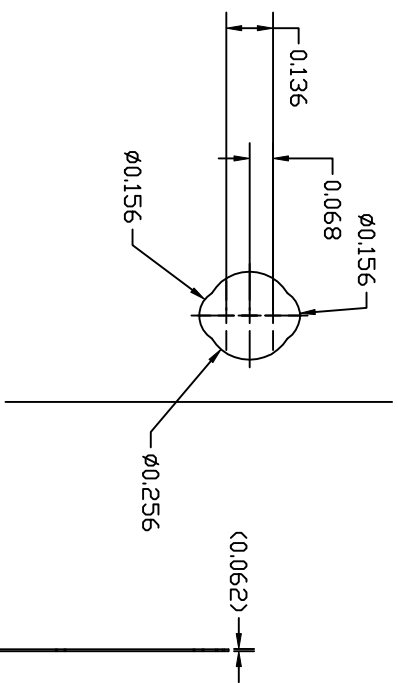

# VIEW A

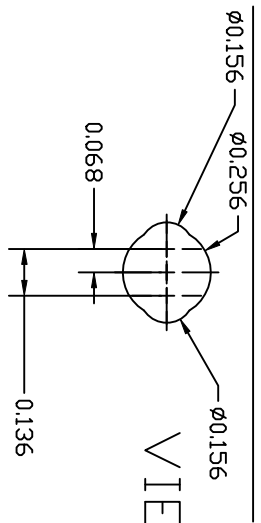

1. THE ORIENTATION OF SIDES "A" AND "B" ARE SHOWN IN VIEW B. ORIENTATION OF SIDES "C" AND "D" ARE SHOWN IN VIEW A.

**NOTES:**  
(UNLESS SPECIFIED)

REV.	DESCRIPTION	DATE

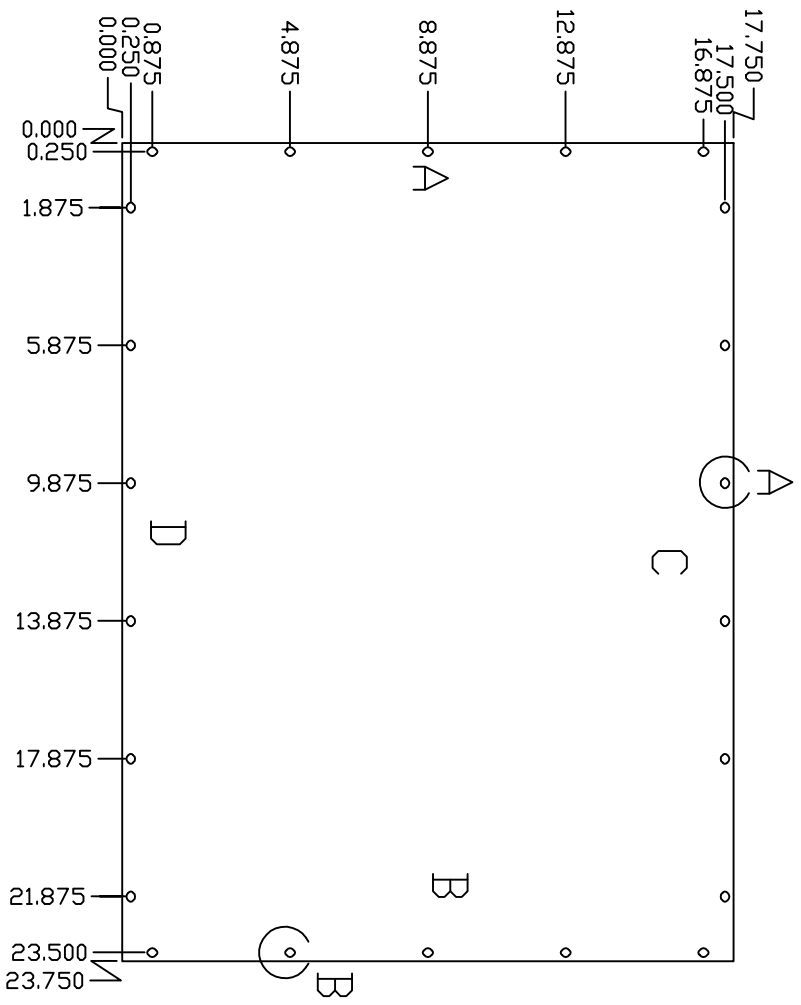

UNLESS OTHERWISE SPECIFIED DIMENSIONS ARE IN INCHES TOLERANCES ARE: X= $\pm 0.03$ ANGLES= $0^\circ 30''$ . XX= $\pm 0.01$ XXX= $\pm 0.005$ FINISH:	TITLE	SIGNATURE	DATE	TEST CONNECTIONS INC. UPLAND, CA
	DR.	MIKE CURTIS	5/30/02	
	CHK.			
MATERIAL:	APP.			

SIZE	DWG NO.	REV
A	4.0 EC 18X24 IP S2-5	
SCALE	NONE	SHEET
		2 OF 5

# VIEW B

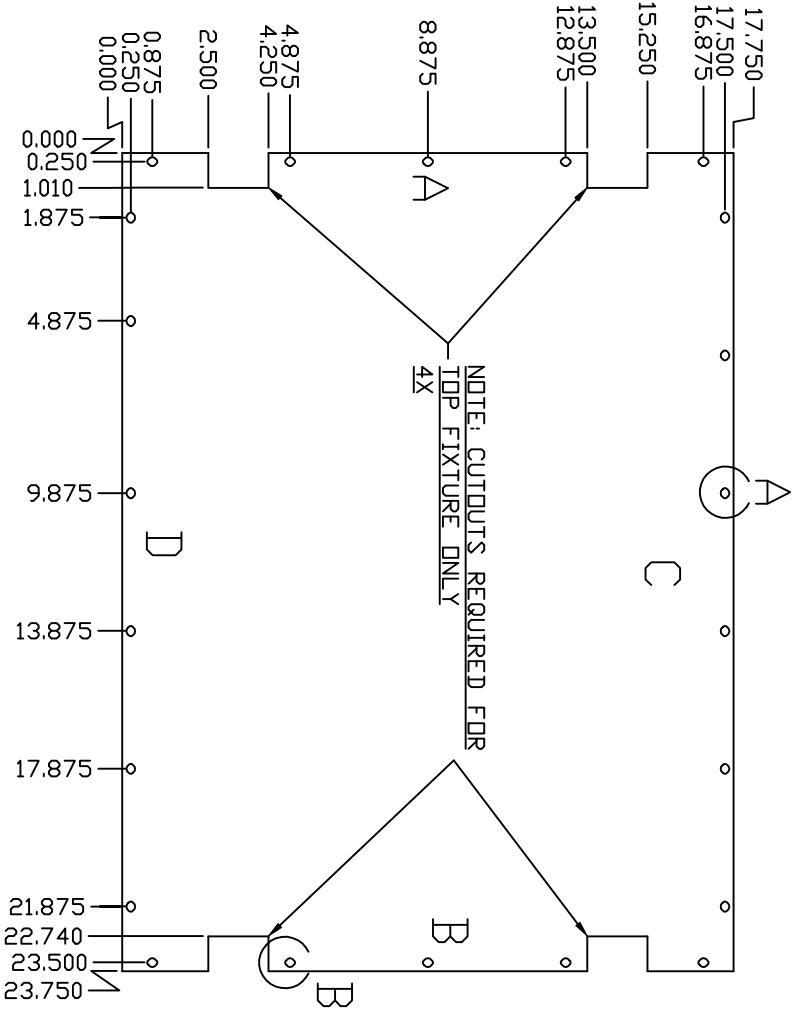
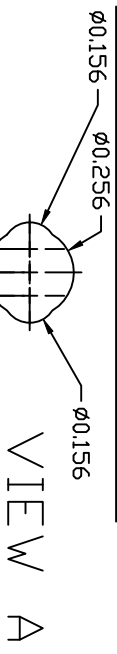
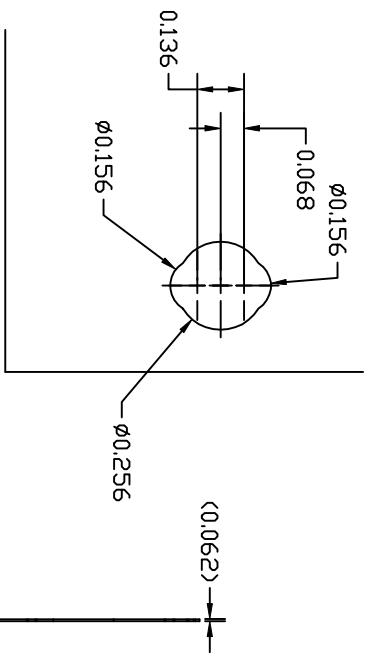

1. THE ORIENTATION OF SIDES "A" AND "B" ARE SHOWN IN VIEW B. ORIENTATION OF SIDES "C" AND "D" ARE SHOWN IN VIEW A.

NOTES:  
(UNLESS SPECIFIED)

REV.	DESCRIPTION	DATE

UNLESS OTHERWISE SPECIFIED DIMENSIONS ARE IN INCHES TOLERANCES ARE: X=±.03 ANGLES=0° 30" XX=±.01 XXX=±.005		TITLE DR. MIKE CURTIS	DATE 5/30/02	TEST CONNECTIONS INC. UPLAND, CA	TITLE 4.0 EC 18X24 INNER PLATE S6	SIZE A	DWG NO. 4.0 EC 18X24 IP S6	REV
FINISH:		APP.	MATERIAL: LEXAN			SCALE NONE	SHEET 3 OF 5	

# VIEW B

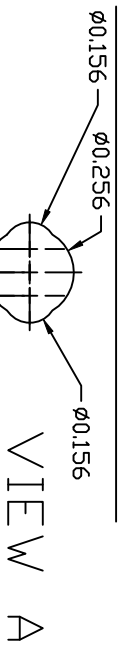
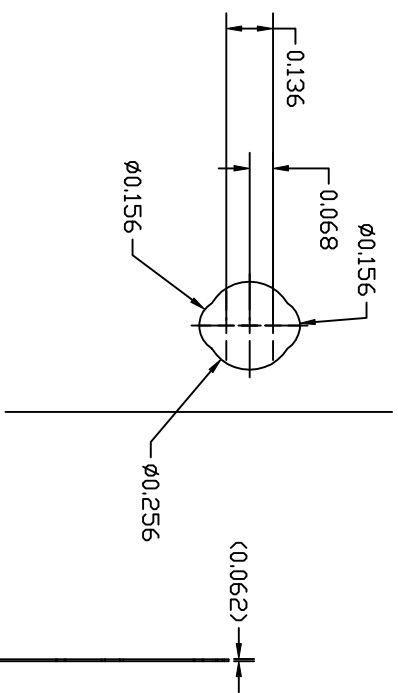

REV.	DESCRIPTION	DATE

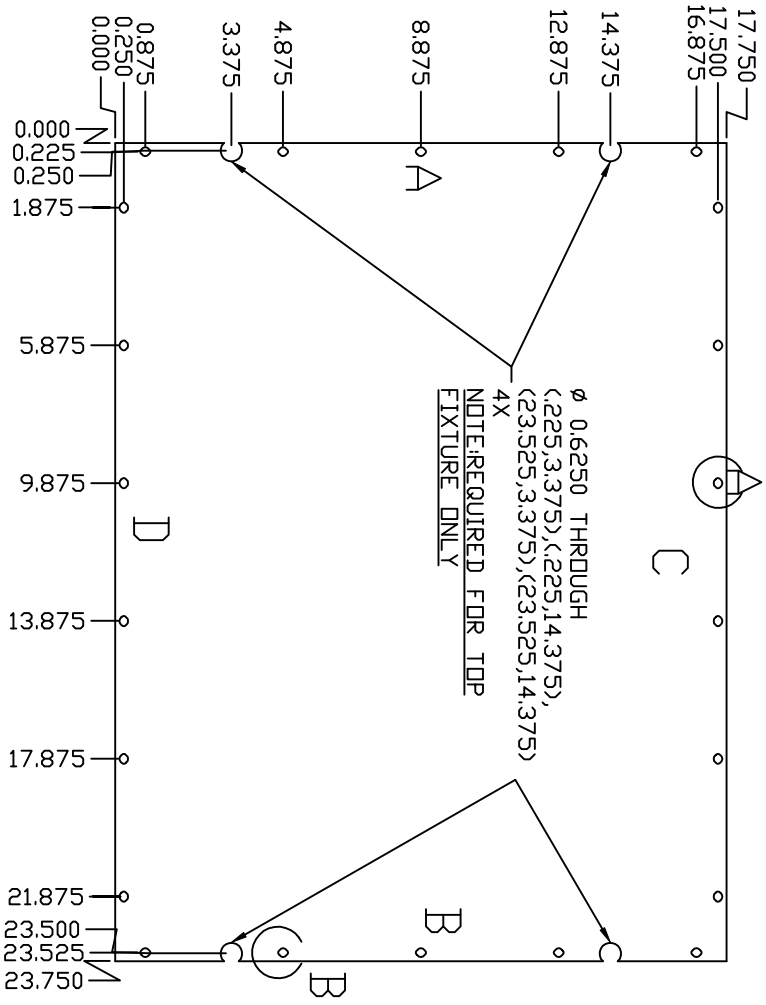

1. THE ORIENTATION OF SIDES "A" AND "B" ARE SHOWN IN VIEW B. ORIENTATION OF SIDES "C" AND "D" ARE SHOWN IN VIEW A.

**NOTES:**  
(UNLESS SPECIFIED)

UNLESS OTHERWISE SPECIFIED DIMENSIONS ARE IN INCHES TOLERANCES ARE: X=±.03 ANGLES=0° 30", XX=±.01 XXX=±.005		TITLE SIGNATURE DR. MIKE CURTIS		DATE 5/30/02
FINISH:		APP.		MATERIAL:
TEST CONNECTIONS INC. UPLAND, CA				
TITLE 4.0 EC 18X24 INNER PLATE S7				
SIZE A	DWG NO. 4.0 EC 18X24 IP S7	REV		
SCALE NONE	SHEET 4 OF 5			

REV.	DESCRIPTION	DATE

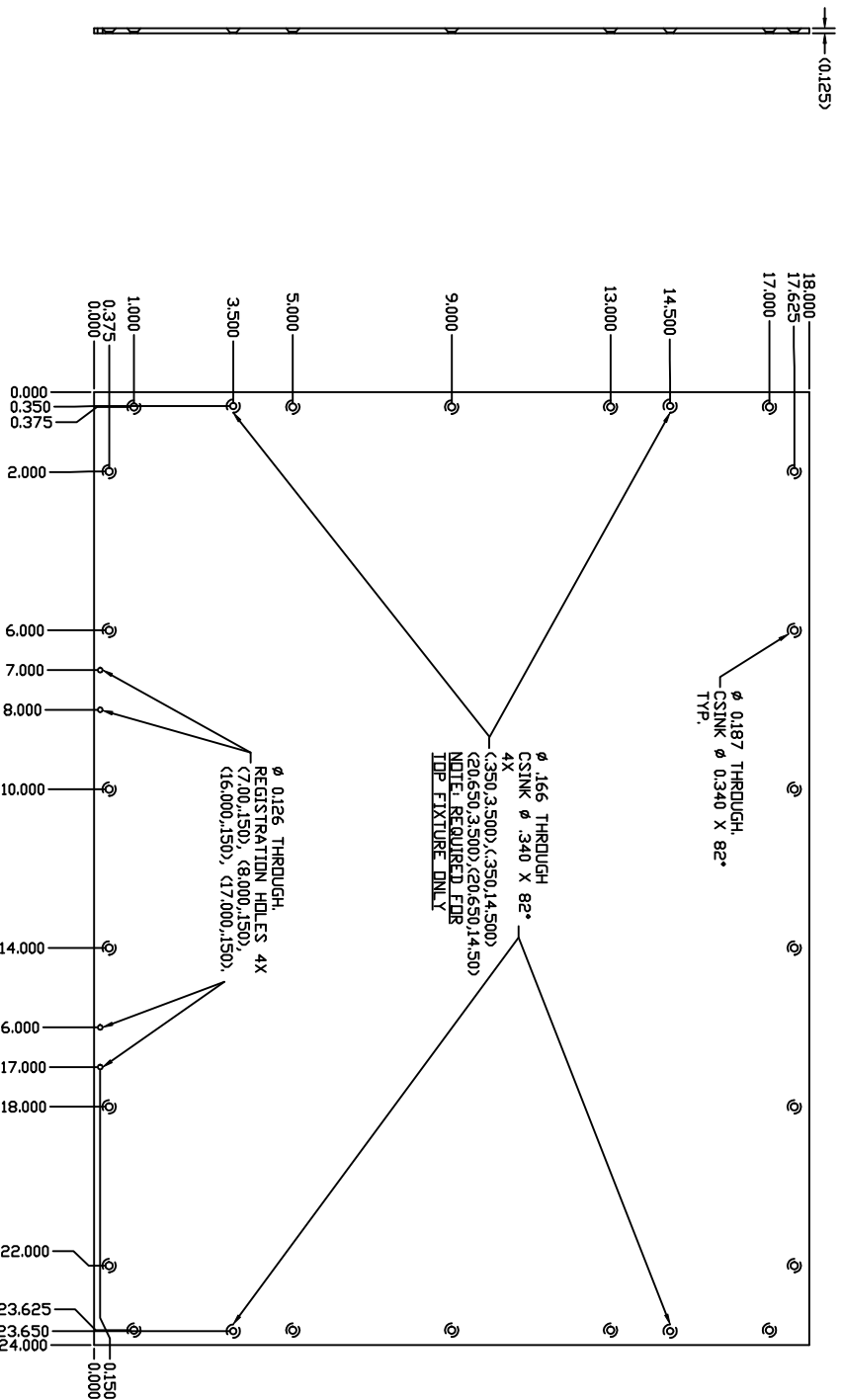

UNLESS OTHERWISE SPECIFIED DIMENSIONS ARE IN INCHES  
 TOLERANCES ARE:  
 X=±.03 ANGLES=0° 30"  
 XX=±.01  
 XXX=±.005

FINISH:

TITLE	SIGNATURE	DATE
DR.	MIKE CURTIS	5/30/02
CHK.		
APP.		

MATERIAL: LEXAN

TITLE: TEST CONNECTIONS INC.  
 UPLAND, CA

4.0 EC 18X24 GRID PLATE S8

SIZE	DWG NO.	REV
A	4.0 EC 18X24 GRID S8	

SCALE NONE SHEET 5 OF 5

NOTES:  
 (UNLESS SPECIFIED)